

100A, 1200V IGBT Module

DESCRIPTION

SGM100PA12A4BTFD Module offers the optimum performance for Auxiliary Inverters, Air Conditioning and Motor Drives.

FEATURES

- ◆ 100A, 1200V, $V_{CE(sat)(typ.)} = 1.7V @ I_C = 100A$
- ◆ $V_{CE(sat)}$ with positive temperature coefficient
- ◆ High short circuit capability
- ◆ Low switching loss
- ◆ Isolated using DBC technology
- ◆ With NTC

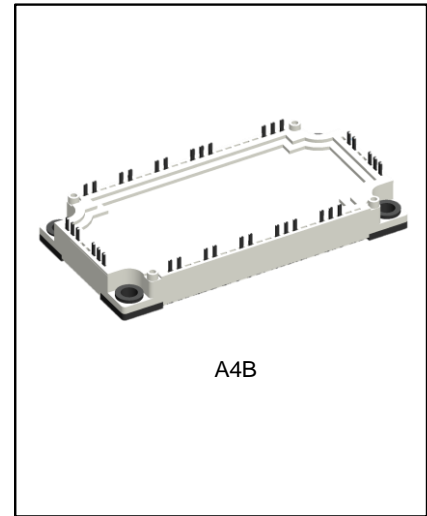

NOMENCLATURE

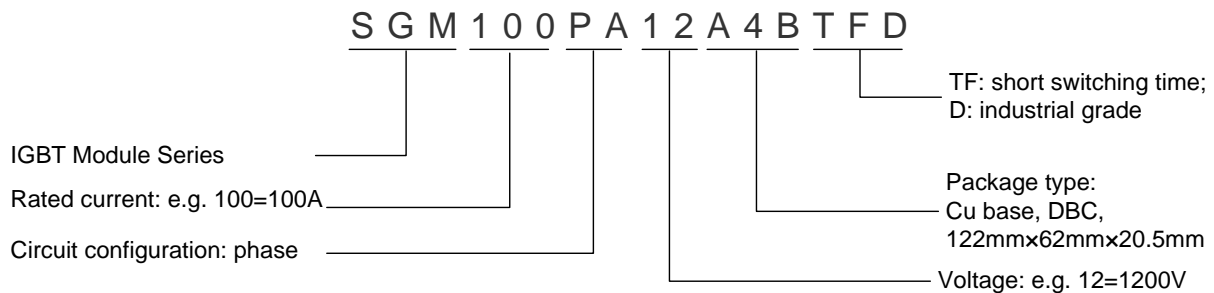

ORDERING INFORMATION

Part No.	Package	Marking	Packing Type
SGM100PA12A4BTFD	A4B	SGM100PA12A4BTFD	Carton

ABSOLUTE MAXIMUM RATINGS OF IGBT INVERTER (T_C = 25°C, UNLESS OTHERWISE NOTED)

Characteristics	Symbol	Test conditions	Ratings	Units
Collector to Emitter Voltage	V_{CES}	$T_j = 25^\circ C$	1200	V
Continuous Collector Current	I_{Cnom}	$T_C = 95^\circ C, T_j \text{ max} = 175^\circ C$	100	A
Repetitive Pulsed Collector Current	I_{CRM}	$t_P = 1ms$	200	A
Total power dissipation	P_{tot}	$T_C = 25^\circ C, T_j \text{ max} = 175^\circ C$	600	W
Gate-Emitter peak voltage	V_{GES}	--	+/-20	V

ELECTRICAL CHARACTERISTICS OF IGBT INVERTER(T_C=25°C UNLESS OTHERWISE NOTED)

Characteristics	Symbol	Test conditions	Min.	Typ.	Max.	Units	
Collector to Emitter Saturation Voltage	V _{CEsat}	I _C =100A, V _{GE} =15V, T _j =25°C	--	1.70	3.0	V	
		I _C =100A, V _{GE} =15V, T _j =125°C	--	1.91	--		
		I _C =100A, V _{GE} =15V, T _j =150°C	--	1.95	--		
Gate Threshold Voltage	V _{GEth}	I _C =250μA, V _{CE} =V _{GE} , T _j =25°C	4.3	5.5	6.8	V	
C-E Leakage Current	I _{CEs}	V _{CE} =1200V, V _{GE} =0V, T _j =25°C	--	--	1	mA	
G-E Leakage Current	I _{GES}	V _{CE} =0V, V _{GE} =20V, T _j =25°C	--	--	500	nA	
Integrated Gate Resistor	R _{Gint}	T _j =25°C	--	4.9	--	Ω	
Input Capacitance	C _{ies}	f=1MHz, T _j =25°C, V _{CE} =25V, V _{GE} =0V	--	9.10	--	nF	
Output Capacitance	C _{oes}		--	3.27	--		
Reverse Transfer Capacitance	C _{res}		--	0.37	--		
Total Gate Charge	Q _G	V _{GE} =-15V---+15V	--	0.86	--	μC	
Turn-On Delay Time	t _{d(on)}	I _C =100A, V _{CE} =600V, V _{GE} =±15V, R _G =35Ω Inductive Load	T _j =25°C	--	0.16	--	μs
			T _j =125°C	--	0.15	--	
			T _j =150°C	--	0.15	--	
Rise Time	t _r		T _j =25°C	--	0.20	--	μs
			T _j =125°C	--	0.21	--	
			T _j =150°C	--	0.21	--	
Turn-Off Delay Time	t _{d(off)}		T _j =25°C	--	0.78	--	μs
			T _j =125°C	--	0.84	--	
			T _j =150°C	--	0.85	--	
Fall Time	t _f	T _j =25°C	--	0.23	--	μs	
		T _j =125°C	--	0.36	--		
		T _j =150°C	--	0.41	--		
Turn-On Switching Loss (per pulse)	E _{on}	T _j =25°C	--	26.3	--	mJ	
		T _j =125°C	--	32.7	--		
		T _j =150°C	--	34.9	--		
Turn-Off Switching Loss(per pulse)	E _{off}	T _j =25°C	--	9.6	--	mJ	
		T _j =125°C	--	12.9	--		
		T _j =150°C	--	13.5	--		
SC data	I _{SC}	V _{GE} =15V, V _{CC} =900V, t _p ≤10μs, T _j =25°C	--	477	--	A	
Thermal Resistance, Junction to Case	R _{θJC}	Per IGBT	--	0.25	--	°C/W	
Thermal Resistance, Case to heatsink	R _{θCH}	Per IGBT	--	0.11	--	°C/W	
Temperature under on-state	T _{jop}	--	-40	--	150	°C	

ELECTRICAL CHARACTERISTICS OF FRD INVERTER(T_c=25°C UNLESS OTHERWISE NOTED)

Characteristics	Symbol	Test conditions	Ratings	Units
Repetitive Reverse Peak Voltage	V _{RRM}	T _j =25°C	1200	V
Continuous Forward DC Current	I _F	--	100	A
Repetitive Reverse Peak Current	I _{FRM}	t _p =1ms	200	A
I ² t-value	I ² t	V _R = 0V, t _p = 10 ms, T _j = 125°C	1450	A ² s
		V _R = 0V, t _p = 10 ms, T _j = 150°C	1400	A ² s

ELECTRICAL CHARACTERISTICS OF FRD INVERTER (T_c=25°C, UNLESS OTHERWISE NOTED)

Characteristics	Symbol	Test conditions	Min.	Typ.	Max.	Units	
Forward Voltage	V _F	I _F =100A, V _{GE} =0V	T _j =25°C	--	2.1	--	V
			T _j =125°C	--	1.8	--	
			T _j =150°C	--	1.7	--	
Reverse Recovery Peak Current	I _{RM}	I _F =100A, -di _F /dt =450A/μs, V _R =600V, V _{GE} =-15V	T _j =25°C	--	46	--	A
			T _j =125°C	--	70	--	
			T _j =150°C	--	76	--	
Recovery Charge	Q _r	I _F =100A, -di _F /dt =450A/μs, V _R =600V, V _{GE} =-15V	T _j =25°C	--	4.46	--	μC
			T _j =125°C	--	12.11	--	
			T _j =150°C	--	15.02	--	
Reverse Recovery Loss (per pulse)	E _{rec}	I _F =100A, -di _F /dt =450A/μs, V _R =600V, V _{GE} =-15V	T _j =25°C	--	1.27	--	mJ
			T _j =125°C	--	4.16	--	
			T _j =150°C	--	5.51	--	
Thermal Resistance, Junction to Case	R _{θJC}	Per diode	--	0.36	--	°C/W	
Thermal Resistance, Case to heatsink	R _{θCH}	Per IGBT	--	0.12	--	°C/W	
Temperature under on-state	T _{jop}	--	-40	--	150	°C	

ABSOLUTE MAXIMUM RATINGS OF IGBT BRAKE (T_c=25°C UNLESS OTHERWISE NOTED)

Characteristics	Symbol	Test conditions	Ratings	Units
Collector to Emitter Voltage	V _{CES}	T _j = 25°C	1200	V
Continuous Collector DC Current	I _{Cnom}	T _c = 95°C, T _j max =175°C	50	A
Repetitive Collector Peak Current	I _{CRM}	t _p = 1ms	100	A
Total Power Loss	P _{tot}	T _c = 25°C, T _j max =175°C	480	W
Gate to Emitter Peak voltage	V _{GES}	--	+/-20	V

ELECTRICAL CHARACTERISTICS OF IGBT BRAKE($T_C=25^{\circ}\text{C}$ UNLESS OTHERWISE NOTED)

Characteristics	Symbol	Test conditions	Min.	Typ.	Max.	Units	
Collector to Emitter Saturation Voltage	V_{CEsat}	$I_C=50A, V_{GE}=15V, T_j=25^{\circ}\text{C}$	--	2.2	2.8	V	
		$I_C=50A, V_{GE}=15V, T_j=125^{\circ}\text{C}$	--	2.4	--		
		$I_C=50A, V_{GE}=15V, T_j=150^{\circ}\text{C}$	--	2.5	--		
Gate Threshold Voltage	V_{GEth}	$I_C=250\mu A, V_{CE}=V_{GE}, T_j=25^{\circ}\text{C}$	4.3	5.1	6.8	V	
Collector to Emitter Off Current	I_{CES}	$V_{CE}=1200V, V_{GE}=0V, T_j=25^{\circ}\text{C}$	--	--	1	mA	
Gate to Emitter Leakage Current	I_{GES}	$V_{CE}=0V, V_{GE}=20V, T_j=25^{\circ}\text{C}$	--	--	500	nA	
Internal Gate Resistance	R_{Gint}	$T_j=25^{\circ}\text{C}$	--	5.3	--	Ω	
Input Capacitance	C_{ies}	$f=400\text{KHz}, T_j=25^{\circ}\text{C}, V_{CE}=25V, V_{GE}=0V$	--	3.61	--	nF	
Output Capacitance	C_{oes}		--	1.12	--		
Reverse Transfer Capacitance	C_{res}		--	0.24	--		
Gate Charge	Q_G	$V_{GE}=-15V\text{---}+15V$	--	0.41	--	μC	
Turn-On Delay Time	$t_{d(on)}$	$I_C=50A, V_{CE}=600V, V_{GE}=\pm 15V, R_G=35\Omega$ Inductive Load	$T_j=25^{\circ}\text{C}$	--	0.08	--	μs
			$T_j=125^{\circ}\text{C}$	--	0.07	--	
			$T_j=150^{\circ}\text{C}$	--	0.07	--	
Rise Time	t_r		$T_j=25^{\circ}\text{C}$	--	0.10	--	μs
			$T_j=125^{\circ}\text{C}$	--	0.10	--	
			$T_j=150^{\circ}\text{C}$	--	0.09	--	
Turn-Off Delay Time	$t_{d(off)}$		$T_j=25^{\circ}\text{C}$	--	0.41	--	μs
			$T_j=125^{\circ}\text{C}$	--	0.44	--	
			$T_j=150^{\circ}\text{C}$	--	0.45	--	
Fall Time	t_f		$T_j=25^{\circ}\text{C}$	--	0.17	--	μs
		$T_j=125^{\circ}\text{C}$	--	0.32	--		
		$T_j=150^{\circ}\text{C}$	--	0.33	--		
Turn-On Switching Loss (per pulse)	E_{on}	$T_j=25^{\circ}\text{C}$	--	6.8	--	mJ	
		$T_j=125^{\circ}\text{C}$	--	8.1	--		
		$T_j=150^{\circ}\text{C}$	--	8.6	--		
Turn-Off Switching Loss(per pulse)	E_{off}	$T_j=25^{\circ}\text{C}$	--	1.9	--	mJ	
		$T_j=125^{\circ}\text{C}$	--	3.3	--		
		$T_j=150^{\circ}\text{C}$	--	3.5	--		
Short-circuit Data	I_{SC}	$V_{GE}=15V, V_{CC}=900V, t_p\leq 10\mu\text{s}, T_j=25^{\circ}\text{C}$	--	250	--	A	
Thermal Resistance, Junction to Case	$R_{\theta JC}$	Per IGBT	--	0.31	--	$^{\circ}\text{C/W}$	
Thermal Resistance, Case to heatsink	$R_{\theta CH}$	Per IGBT	--	0.12	--	$^{\circ}\text{C/W}$	
Temperature under on-state	T_{jop}	--	-40	--	150	$^{\circ}\text{C}$	

ABSOLUTE MAXIMUM RATINGS OF FRD BRAKE (T_c=25°C UNLESS OTHERWISE NOTED)

Characteristics	Symbol	Test conditions	Ratings	Units
Repetitive Reverse Peak Voltage	V _{RRM}	T _j = 25°C	1200	V
Continuous Forward DC Current	I _F	--	25	A
Repetitive Reverse Peak Current	I _{FRM}	t _p = 1ms	50	A
I ² t-value	I ² t	V _R = 0V, t _p = 10 ms, T _j = 125°C	85	A ² s
		V _R = 0V, t _p = 10 ms, T _j = 150°C	75	A ² s

ELECTRICAL CHARACTERISTICS OF FRD BRAKE (T_c=25°C UNLESS OTHERWISE NOTED)

Characteristics	Symbol	Test conditions	Min.	Typ.	Max.	Units	
Forward Voltage	V _F	I _F = 25A	T _j = 25°C	--	2.1	--	V
			T _j = 125°C	--	1.7	--	
			T _j = 150°C	--	1.6	--	
Reverse Recovery Peak Current	I _{RM}		T _j = 25°C	--	31	--	A
			T _j = 125°C	--	48	--	
			T _j = 150°C	--	52	--	
Recovery Charge	Q _r	I _F = 25A, -di _F /dt = 450A/μs, V _R = 600V, V _{GE} = -15V	T _j = 25°C	--	1.69	--	μC
			T _j = 125°C	--	4.45	--	
			T _j = 150°C	--	5.22	--	
Reverse Recovery Loss (per pulse)	E _{rec}		T _j = 25°C	--	0.73	--	mJ
			T _j = 125°C	--	1.92	--	
			T _j = 150°C	--	2.35	--	
Thermal Resistance, Junction to Case	R _{θJC}	Per diode	--	0.94	--	°C/W	
Thermal Resistance, Case to heatsink	R _{θCH}	Per IGBT	--	0.14	--	°C/W	
Temperature under on-state	T _{jop}	--	-40	--	150	°C	

ABSOLUTE MAXIMUM RATINGS OF DIODE, RECTIFIER (T_c=25°C UNLESS OTHERWISE NOTED)

Characteristics	Symbol	Test conditions	Ratings	Units
Repetitive Reverse Peak Voltage	V _{RRM}	T _j = 25°C	1600	V
Forward Surge Current	I _{FSM}	t _p = 10 ms, T _j = 25°C	1000	A
		t _p = 10 ms, T _j = 150°C	720	A
I ² t-value	I ² t	t _p = 10 ms, T _j = 25°C	6200	A ² s
		t _p = 10 ms, T _j = 150°C	3400	A ² s

ELECTRICAL CHARACTERISTICS OF DIODE, RECTIFIER (T_C=25°C UNLESS OTHERWISE NOTED)

Characteristics	Symbol	Test conditions	Min.	Typ.	Max.	Units
Forward Voltage	V _F	I _F =100A, T _j =150°C	--	1.2	--	V
Reverse Current	I _R	V _R =1600V, T _j =150°C	--	--	1.0	mA
Thermal Resistance, Junction to Case	R _{θJC}	Per Diode	--	0.50	--	°C/W
Thermal Resistance, Case to heatsink	R _{θCH}	Per Diode	--	0.12	--	°C/W
Temperature under on-state	T _{jop}	--	-40	--	150	°C

NTC—THERMISTOR(SPECIFICATION ACCORDING TO THE VALID APPLICATION NOTE)

Characteristics	Symbol	Test conditions	Min.	Typ.	Max.	Units
Rated resistance	R ₂₅	T _C =25°C	--	5	--	KΩ
Deviation of R100	ΔR/R	T _C =100°C, R100=10mW	-5	--	5	%
B-value	B _{25/50}	R ₂ =R ₂₅ exp [B _{25/50} (1/T ₂ -1/(298,15K))]	--	3380	--	K
B-value	B _{25/85}	R ₂ =R ₂₅ exp [B _{25/85} (1/T ₂ -1/(298,15K))]	--	3435	--	K

MODULE(T_C=25°C, UNLESS OTHERWISE NOTED)

Characteristics	Symbol	Test conditions	Ratings	Units
Insulation test voltage	V _{ISOL}	RMS, f=50Hz, t=1min	2.5	kV
Material for internal insulation	--	--	Cu	--
internal insulation	--	Insulation (class 1, IEC 61140)	Al ₂ O ₃	--
Creepage distance	--	Terminal-heatsink	10	mm
		Terminal - terminal	--	mm
Clearance distance	--	Terminal-heatsink	7.5	mm
		Terminal - terminal	--	mm
Comparative tracking index	CTI	--	>200	--

MODULE THERMAL CHARACTERISTICS(T_C =25°C, UNLESS OTHERWISE NOTED)

Characteristics	Symbol	Test conditions	Min.	Typ.	Max.	Units
Stray inductance module	L _{sCE}	--	--	40	--	nH
Storage temperature	T _{stg}	--	-40	--	125	°C
Mounting torque	M	Screw M5	3.0	--	6.0	Nm
Weight	G	--	--	300	--	g

TYPICAL CHARACTERISTICS CURVE(IGBT, INVERTER)

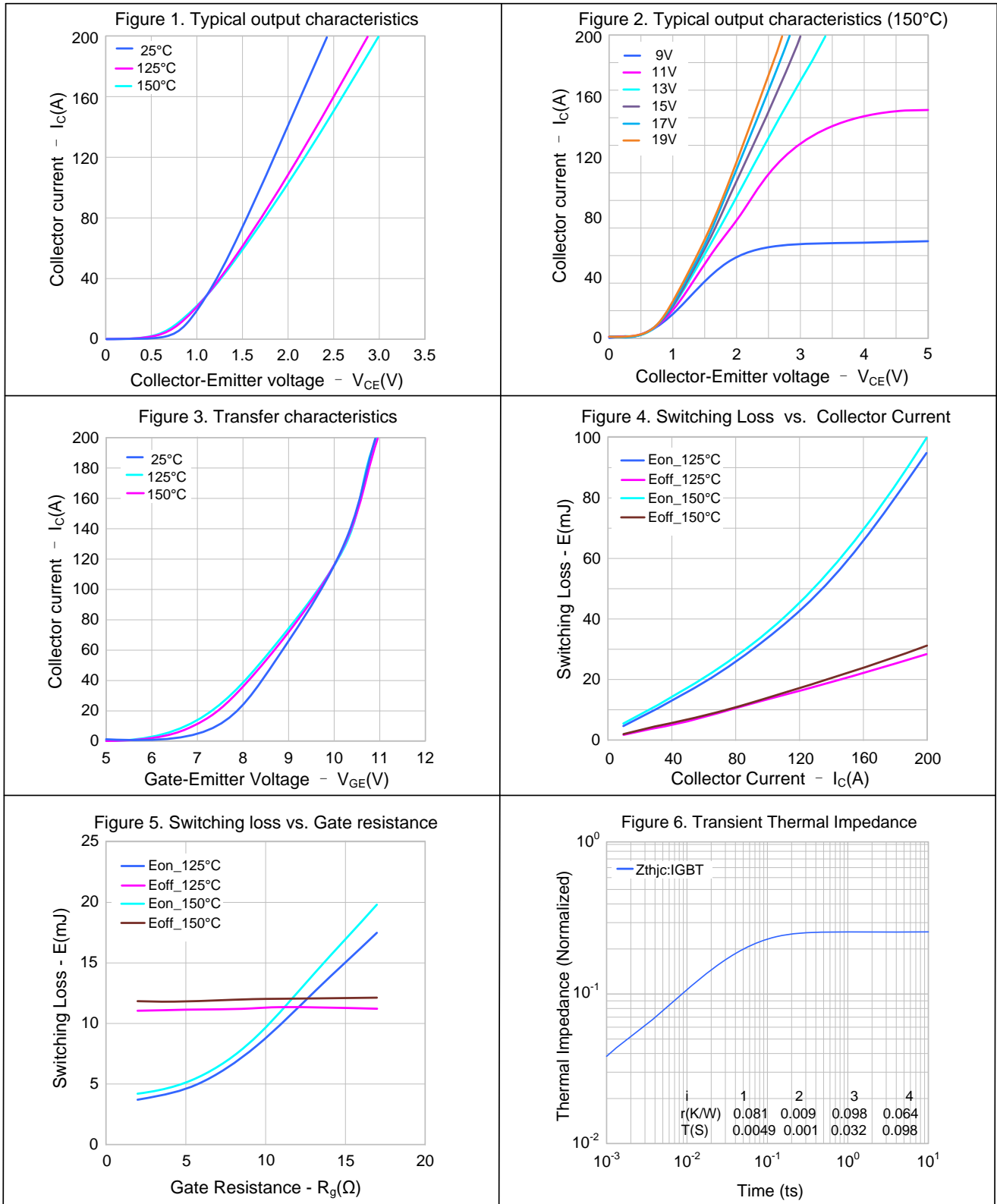

TYPICAL CHARACTERISTICS CURVE (IGBT, INVERTER) (CONTINUED)

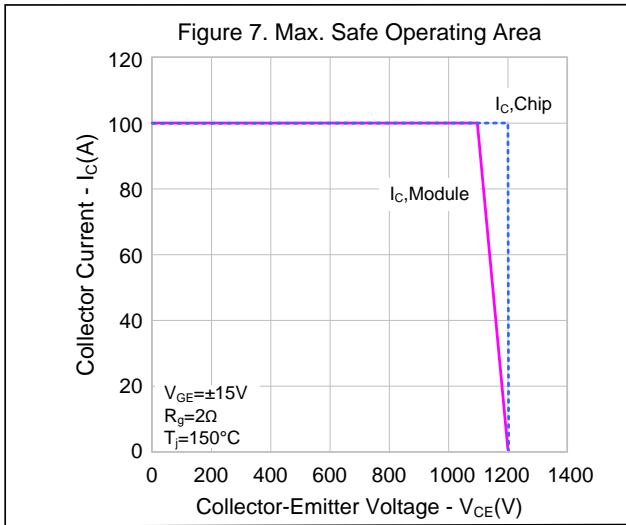

TYPICAL CHARACTERISTICS CURVE (FRD, INVERTER) (CONTINUED)

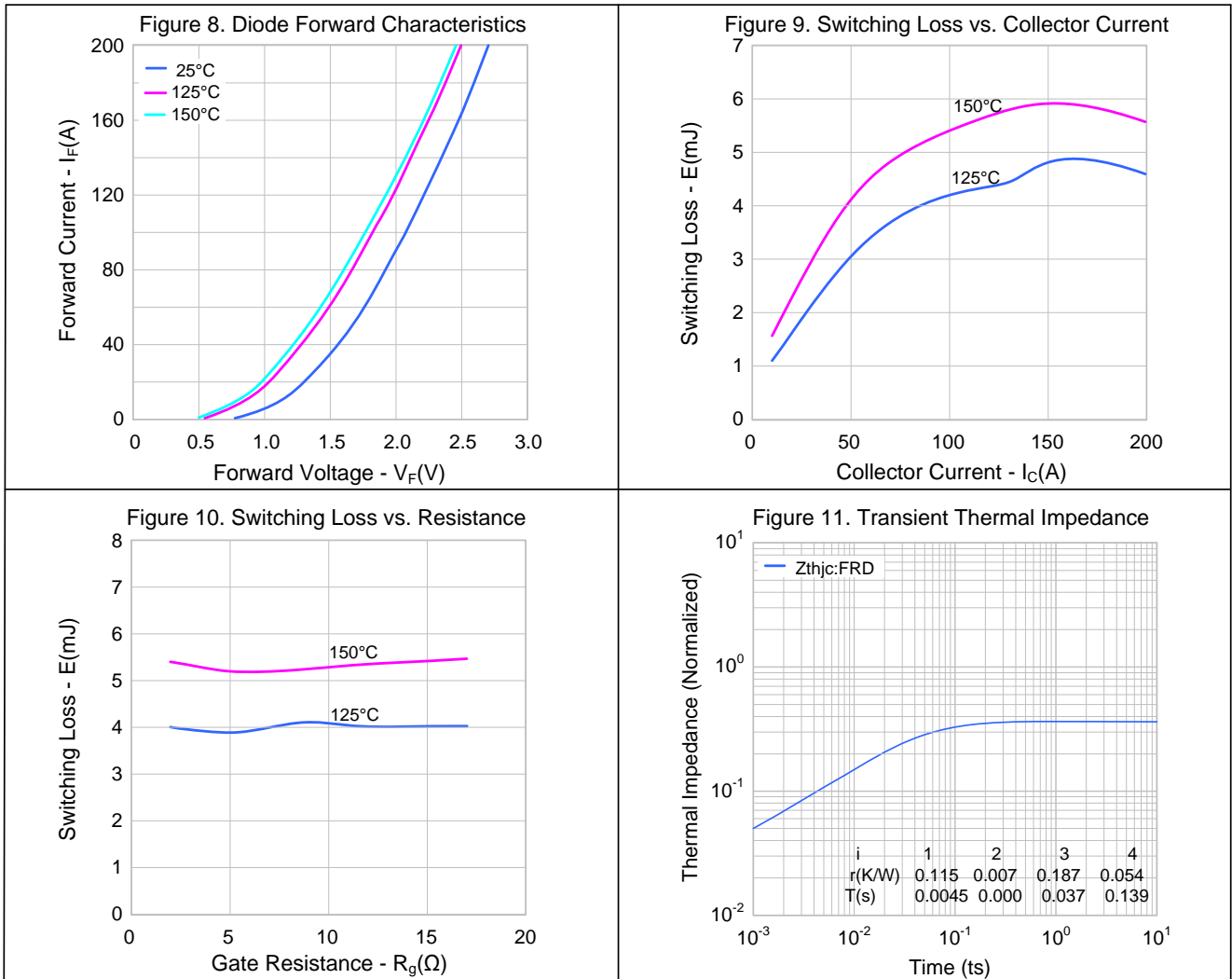

TYPICAL CHARACTERISTICS CURVE (DIODE, RECTIFIER)

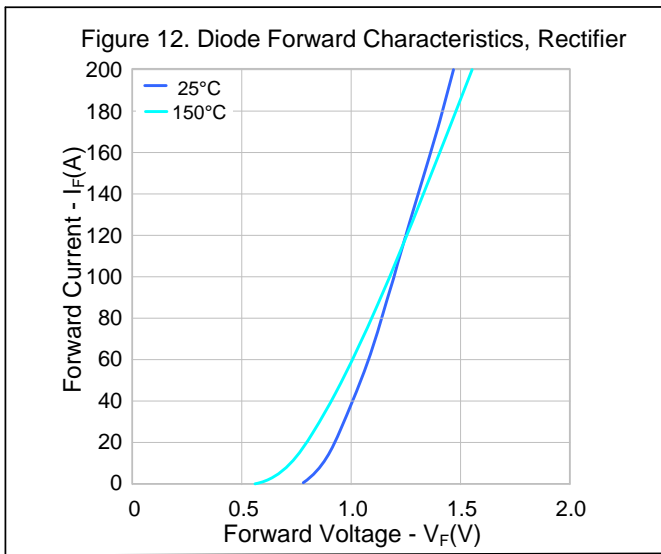

TYPICAL CHARACTERISTICS CURVE (BRAKE)

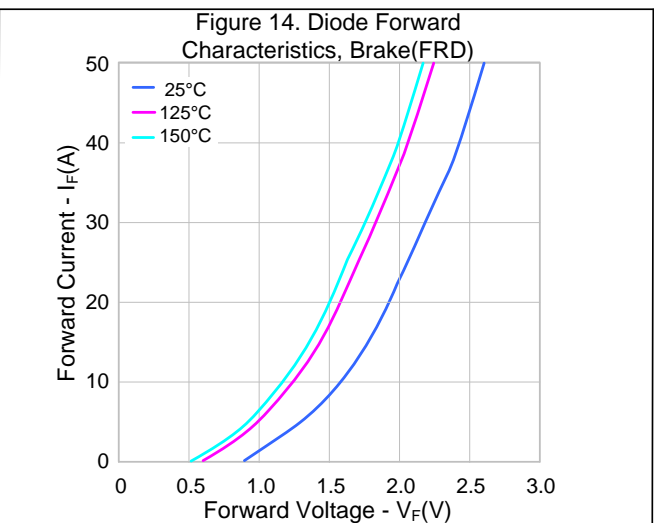
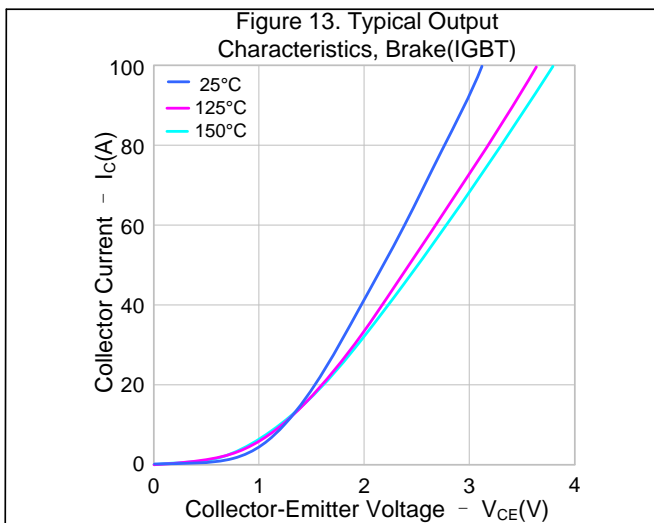

TYPICAL CHARACTERISTICS CURVE (NIC-THERMISTOR)

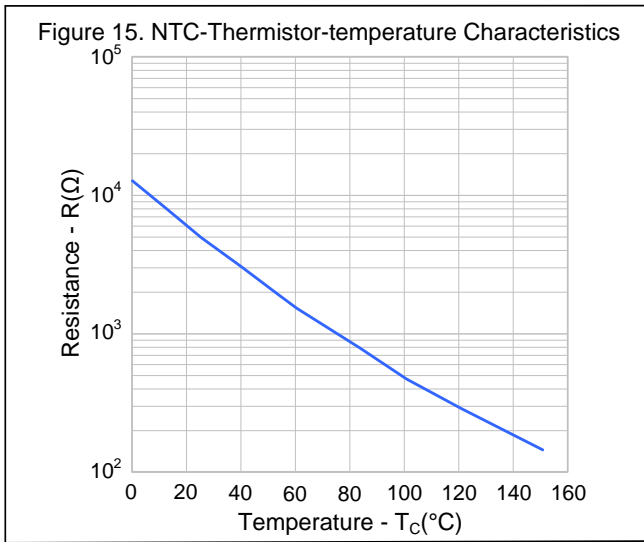

CIRCUIT DIAGRAM

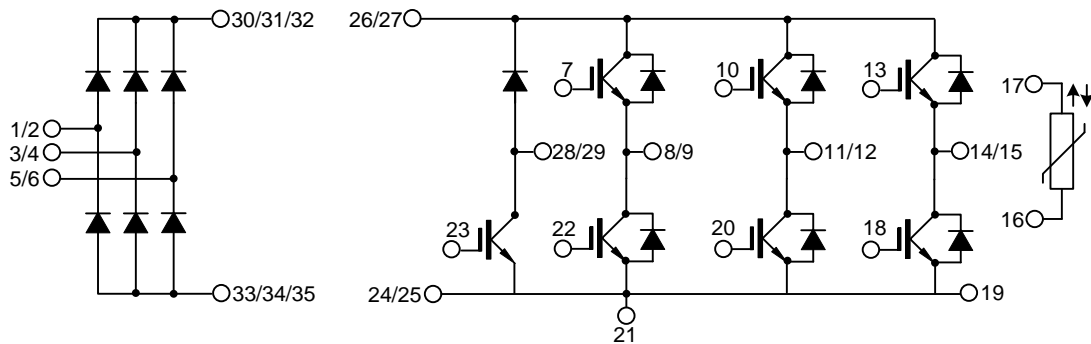

PACKAGE OUTLINE

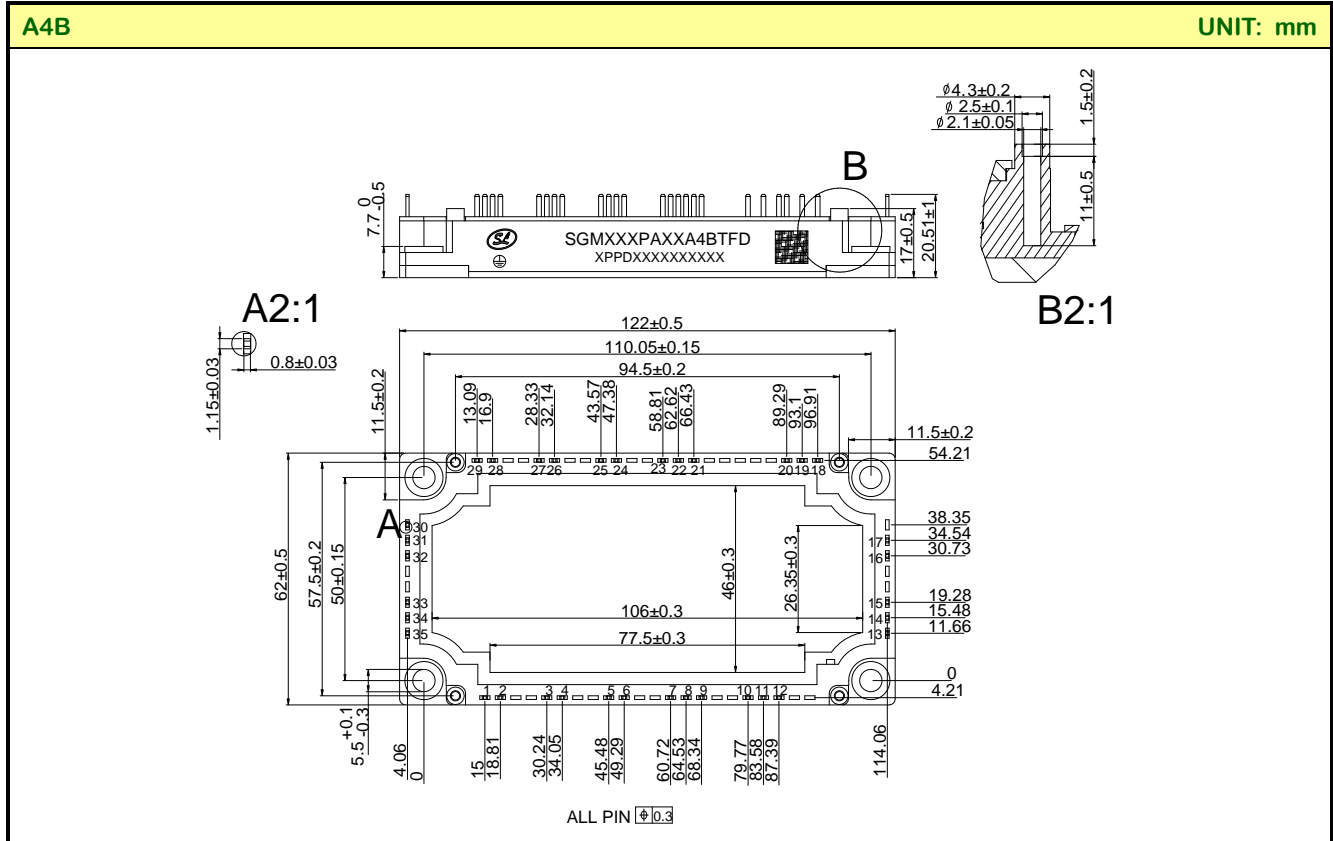

Important notice :

- The instructions are subject to change without notice! Customers should obtain the latest relevant information before placing orders and should verify that such information is complete and current.
- Our products are consumer electronic products, and / or civil electronic products.
- When using our products, please do not exceed the maximum rating of the products, otherwise the reliability of the whole machine will be affected. There is a certain possibility of failure or malfunction of any semiconductor product under specific conditions. The buyer is responsible for complying with safety standards and taking safety measures when using our products for system design, sample and whole machine manufacturing, so as to avoid potential failure risk that may cause personal injury or property loss.
- It is strongly recommended to identify the trademark when buying our products. Please contact us if there is any question.
- When exporting, using and reselling our products, buyer must comply with the international export control laws and regulations of China, the United States, the United Kingdom, the European Union and other countries & regions.
- Product promotion is endless, our company will wholeheartedly provide customers with better products!
- Website: <http://www.silan.com.cn>

Part No.: SGM100PA12A4BTFD Document Type: Datasheet
Copyright: HANGZHOU SILAN MICROELECTRONICS CO.,LTD Website: <http://www.silan.com.cn>

Rev.: 1.3

Revision History:

1. Update the template of the datasheet
-

Rev.: 1.2

Revision History:

1. Update the package outline
-

Rev.: 1.1

Revision History:

1. Update the Electrical characteristics of capacitance
-

Rev.: 1.0

Revision History:

1. First release
-